

Town of Madbury

[Print Now](#)

Parcel ID: 000009 000060 0000G0 (CARD 1 of 1)
 Owner: LABABIDI FAMILY REVOCABLE TRUST OF 2020
 LABABIDI, ZIAD & RAYANN NAWI CO-TRUSTEES
 Location: 21 GARRISON LANE
 Acres: 1.250

General

Valuation		Listing History	
Building Value:	\$236,100	List Date	Lister
Features:	\$4,300	08/02/2019	RWVM
Taxable Land:	\$122,100	02/29/2016	CRPM
<hr/>		10/14/2014	KCVM
Card Value:	\$362,500	03/29/2011	CRPR
Parcel Value:	\$362,500	11/01/2006	MAIL
Review and Pay Property Taxes Online			

Notes: TAN; 3/11 MRS DIDN'T WANT PICTURE TAKEN & VERIFIED INFO FROM EXT; 10/14. NOH; CORR SIDING/VLT; REPAIRING SILLS ON PRS; 8/19: CORR OPF TO FFF/PRS, PU DECK 25X12, NEEDS SOME SIDING, HO BAD TIME, DNVI;

Sales

Sale Date	Sale Type	Qualified	Sale Price	Grantor	Book	Page
06/02/2020	IMPROVED	NO - FAMILY/RELAT GRNTR/E	\$1	LABABIDI, ZIAD	4766	0973
07/26/2005	IMPROVED	NO - DEED DATE OLD/INCMP	\$225,000	AYESTAS, ANGEL&MARTHA	3228	828
06/10/2002	IMPROVED	YES	\$255,000	SUNDBERG, D & N	2524	0774
05/10/2001	IMPROVED	YES	\$150,000	SUNDBERG, D & J	2309	0209
08/23/1978	IMPROVED	YES	\$59,900	CHENEY	1020	0324

Land

Size: 1.250 Ac.
Zone: 01 - RA RESIDENTIAL AGRI
Neighborhood: AVG +10
Land Use: 1F RES

Site: AVERAGE
Driveway: PAVED
Road: PAVED

Taxable Value: \$122,100

Land Type	Units	Base Rate	NC	Adj	Site	Road	Dway	Topo	Cond	Ad Valorem	SPI	R	Tax Value	Notes
1F RES	1.250 AC	123,012	F	110	100	100	100	95 MILD	95	122,100	0	N	122,100	PLE

Building

2.00 STORY FRAME COLONIAL Built In 1978

Roof: GABLE OR HIP
 ASPHALT
Exterior: CLAP BOARD
Interior: DRYWALL
Flooring: CARPET
Heat: OIL
 HOT WATER

Bedrooms: 4
Bathrooms: 1.5
Extra Kitchens: 0
Fireplaces: 0
Generators: 0
AC: NO

Quality: AVG+10
Size Adj. 0.9737
Base Rate: 98.00
Building Rate: 0.9871
Sq. Foot Cost: 96.74
Effective Area: 2,906
Gross Living Area: 2,666
Cost New: \$281,126

Depreciation						
Normal GOOD	Physical	Functional	Economic	Temporary	Total Dpr.	Assessment
16%	0%	0%	0%	0%	16%	\$236,100

Features

Feature Type	Units	Length x Width	Size Adj	Rate	Cond	Value	Notes
FIREPLACE 1-STAND	1		100	3000.00	100	\$3,000	
SHED-WOOD	96	8 x 12	227	10.00	60	\$1,308	
Total:						\$4,300	

Photo



Sketch

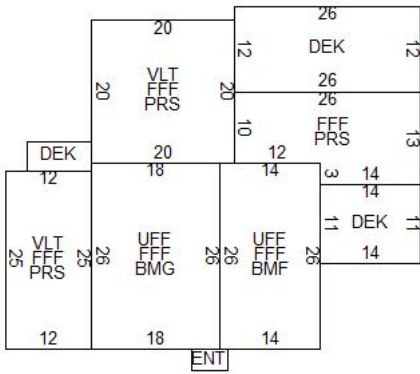

Code	Description	Area	Eff Area	GL Area
FFF	FST FLR FIN	1,834	1,834	1,834
UFF	UPPER FLR FIN	832	832	832
BMF	BSMNT FINISHED	364	109	0
BMG	BASEMENT GARAGE	468	94	0
DEK	DECK/ENTRANCE	502	50	0
ENT	ENTRY WAY	15	2	0
PRS	PIER FOUNDATION	1,002	-50	0
VLT	VAULTED	700	35	0
Totals			2,906	2,666

Printed on 05-18-23